

Frame Kit Installation Instructions

Retractable Pleated Insect Screen



Read Installation Instructions carefully before proceeding
Ensure that Installation Instructions remain with homeowner.



WARNING

Screen will not stop children from falling out window
Keep children away from open window
A safety initiative from the Australian Window Association



Recommended Tools

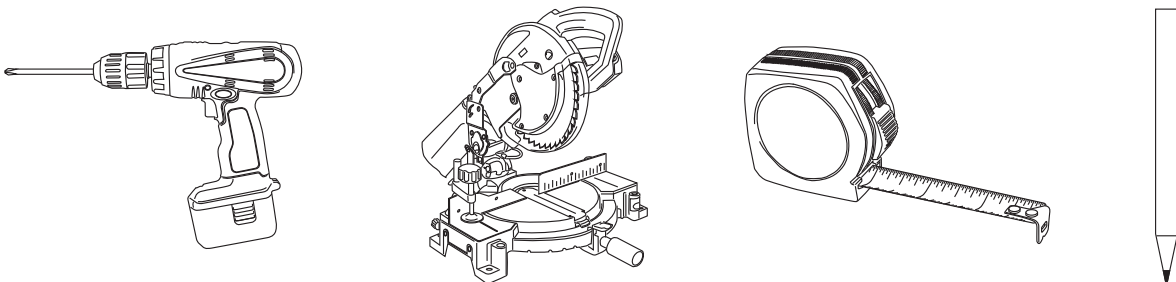

NOTE: DO NOT USE CIRCULAR SAW
LAMINATE NON-FERROUS METAL BLADE

"L" Kit Components

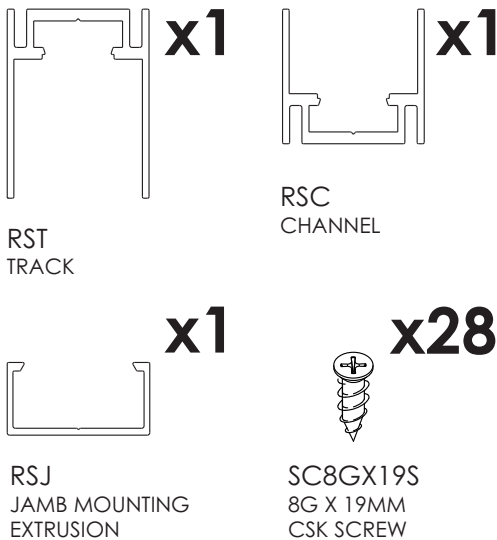

"T" Kit Components

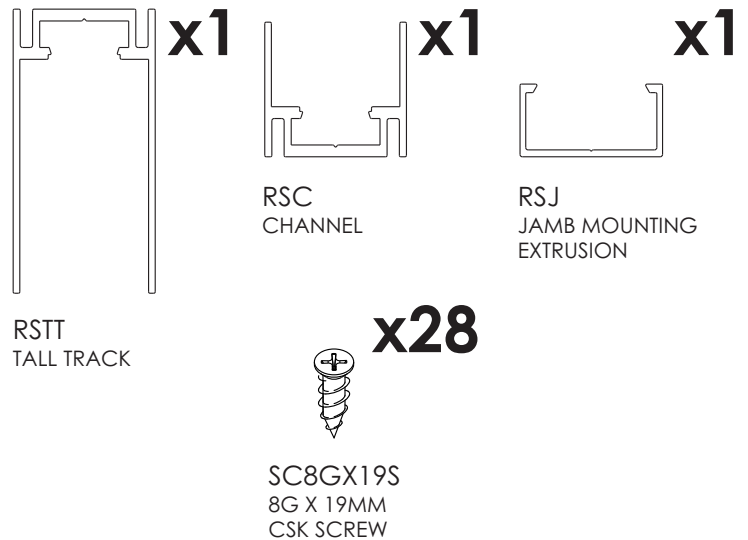

Cutting RST or RSTT and RSC

All dimensions are in inches (mm)

Measure the internal frame opening width (W).

Note: Jamb may be rebated (example shown below)

Depending on the size of the frame RST or RSTT and RSC can be supplied in 2 lengths)

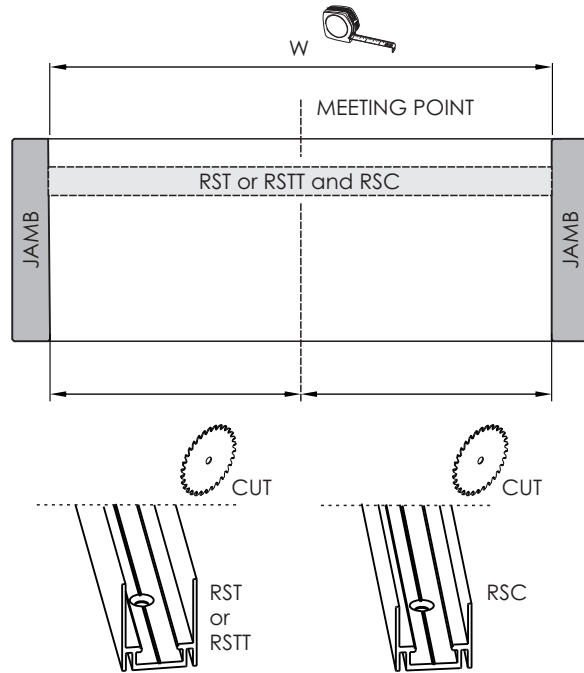
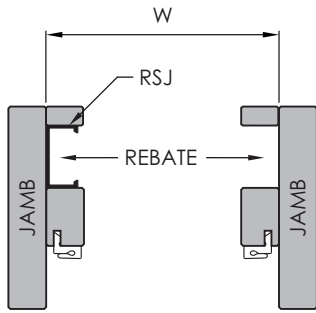

Cutting RSJ | single or double screen

Measure the internal frame opening height (H).

Note: Head and Threshold may be rebated (as shown below)

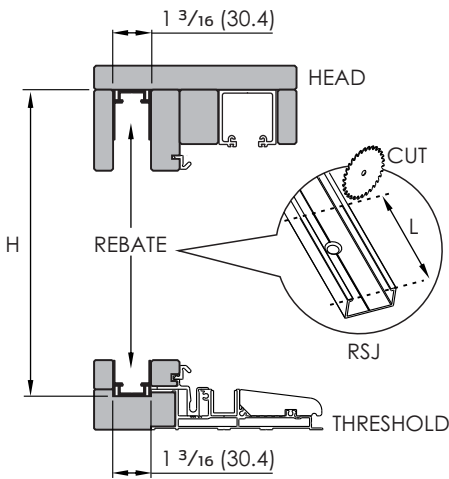

Length of RSJ (L) = H - X*

* X = 2 3/4 (70) (RST + RSC + 1/16 (1.5))

* X = 3 9/16 (90) (RSTT + RSC + 1/16 (1.5))

Note: For a double screen install, 2 x RSJ extrusions are to be cut and installed

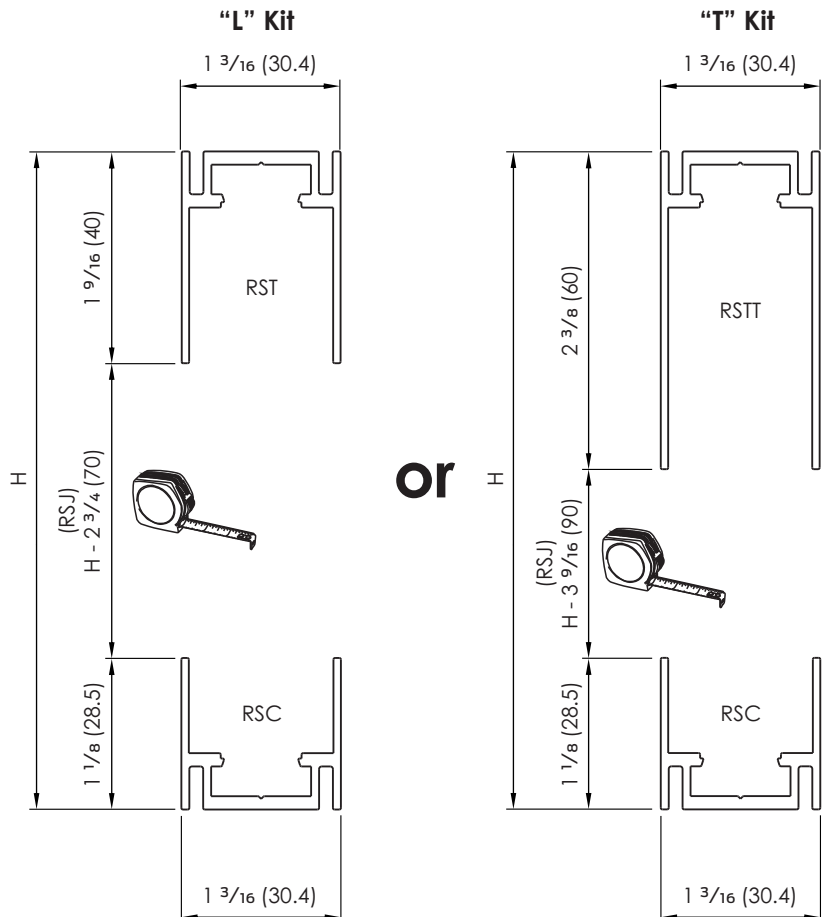

Cutting RSJ | corner double screen

Measure the internal frame opening frame height (H).

Note: Head and Threshold may be rebated (as shown below)

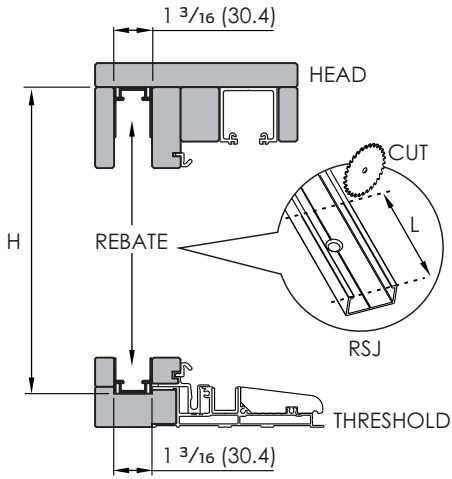

Length of RSJ (L) = H - X*

* X = 2 3/4 (70) (RST + RSC + 1/16 (1.5))

* X = 3 9/16 (90) (RSTT + RSC + 1/16 (1.5))

Note: For a corner double screen install, 2 x RSJ extrusions are to be cut and installed

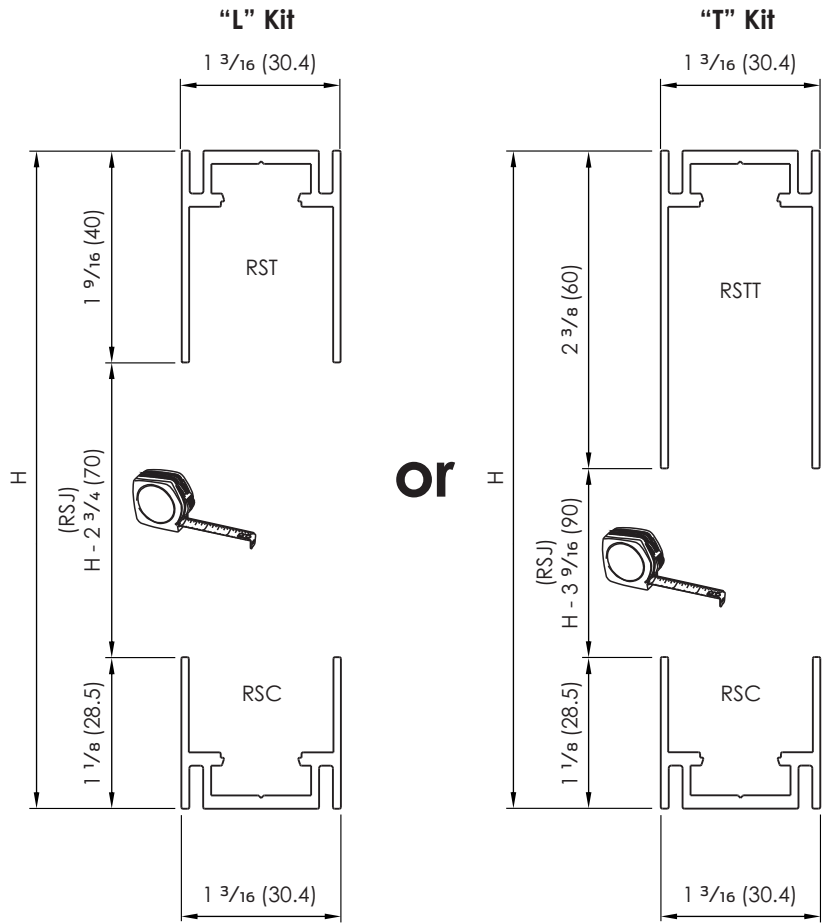

Cutting RST or RSTT and RSC | open joint

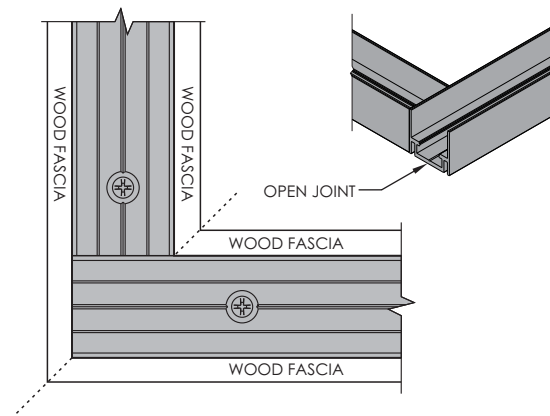
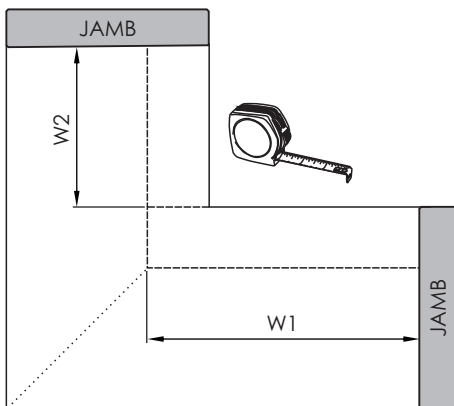

Length of RSC (W2) / RST or RSTT (W2) = W2
and

Length of RSC (W1) / RST or RSTT (W1) = W1

Fitting Frame | single screen

RSC, RSTT and RSJ have been supplied pre-drilled.
Place profiles into position and screw fix using screws (SC8GX19S)

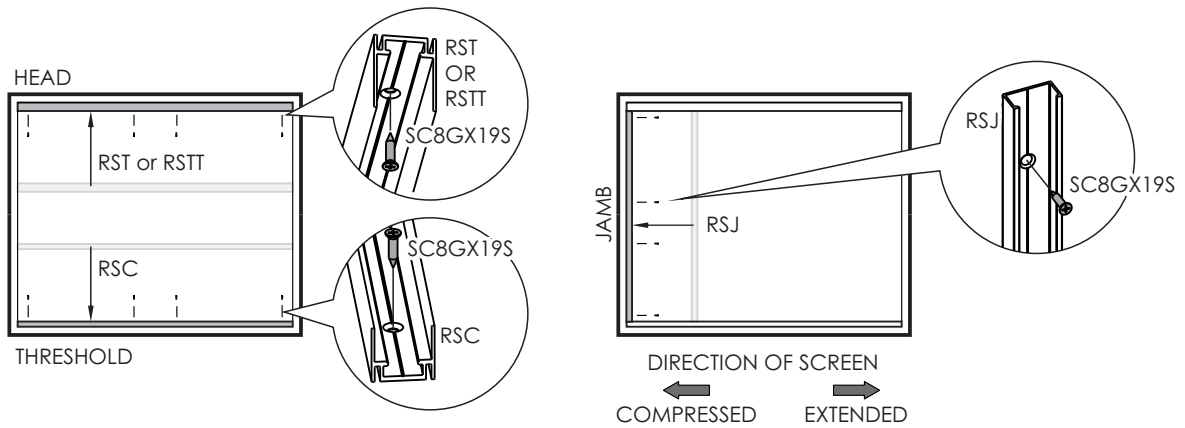

Fitting Frame | double screen

RSC, RSTT and RSJ have been supplied pre-drilled.
Place profiles into position and screw fix using screws (SC8GX19S)

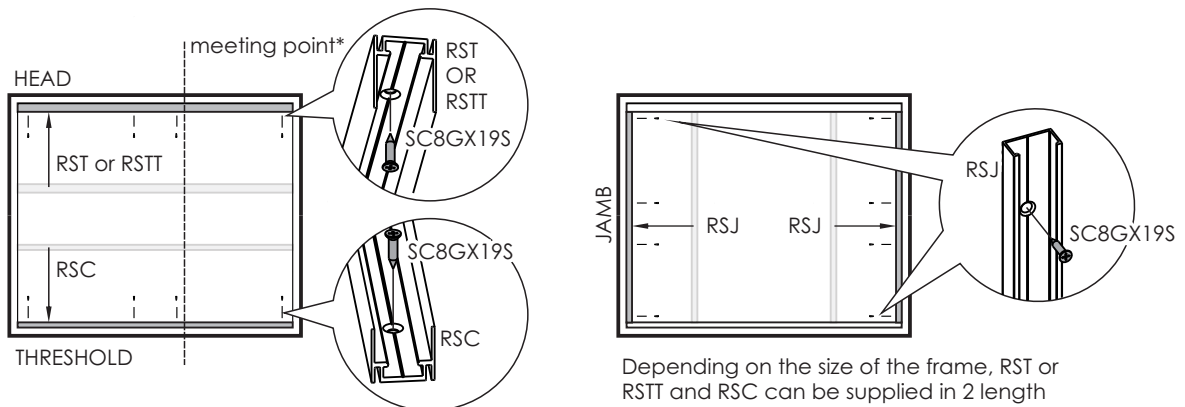

Fitting Frame | corner double screen

RSC, RSTT and RSJ have been supplied pre-drilled.
Place profiles into position and screw fix using screws (SC8GX19S)

